

The Process
of
Building LANDIS-II

Jimm Domingo

University of Wisconsin-Madison

July 13, 2004

Software Development Before LANDIS-II

- Tools and Process – LANDIS 4.0
 - Unified Modeling Language (UML)
Tutorial from Trireme International
 - Unified Process Model (UPM)

Unification of Notation in Software Methodologies

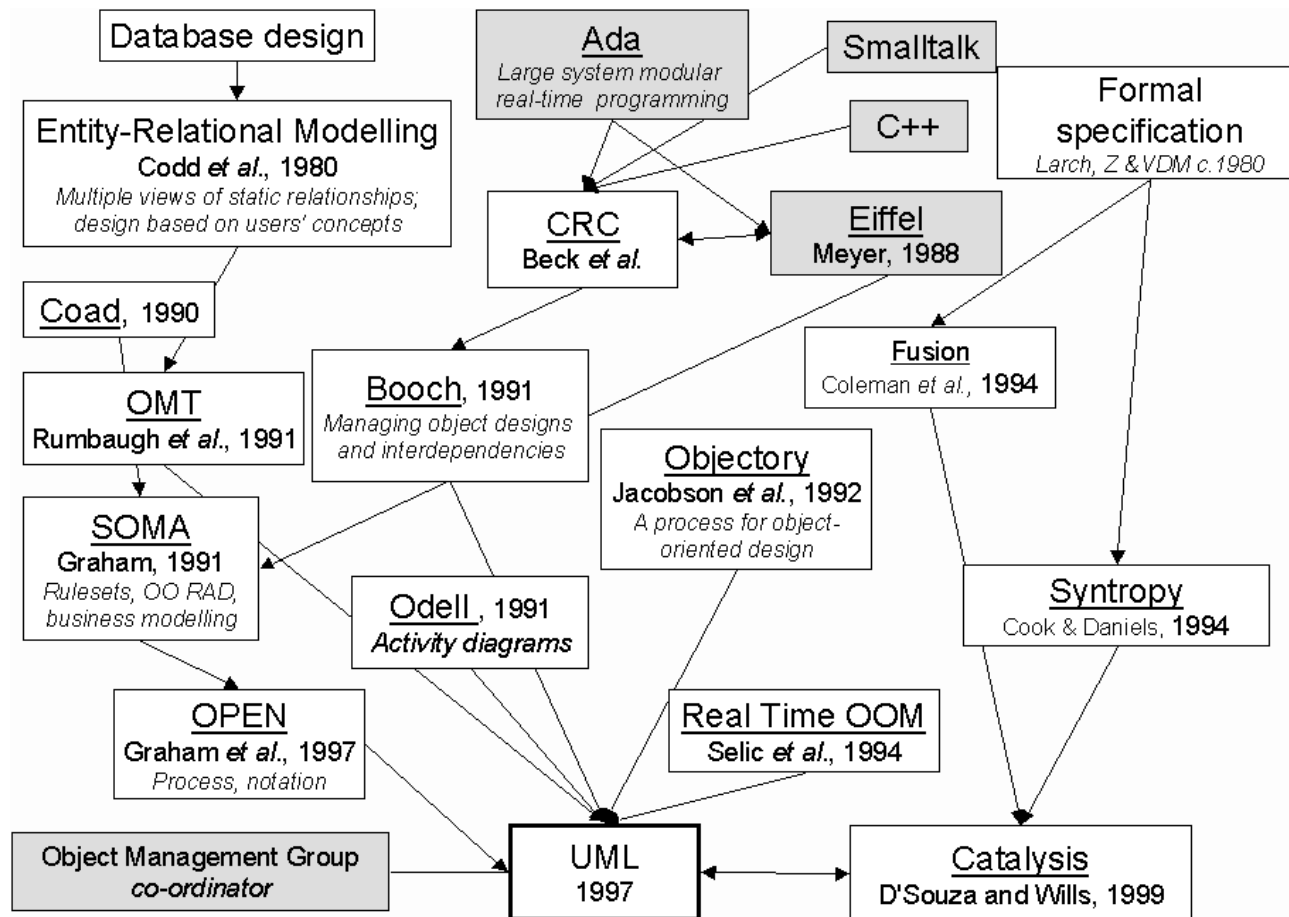

Figure 1, UML – a tutorial, ©1999 Tirreme International

UML Designed by The 3 Amigos

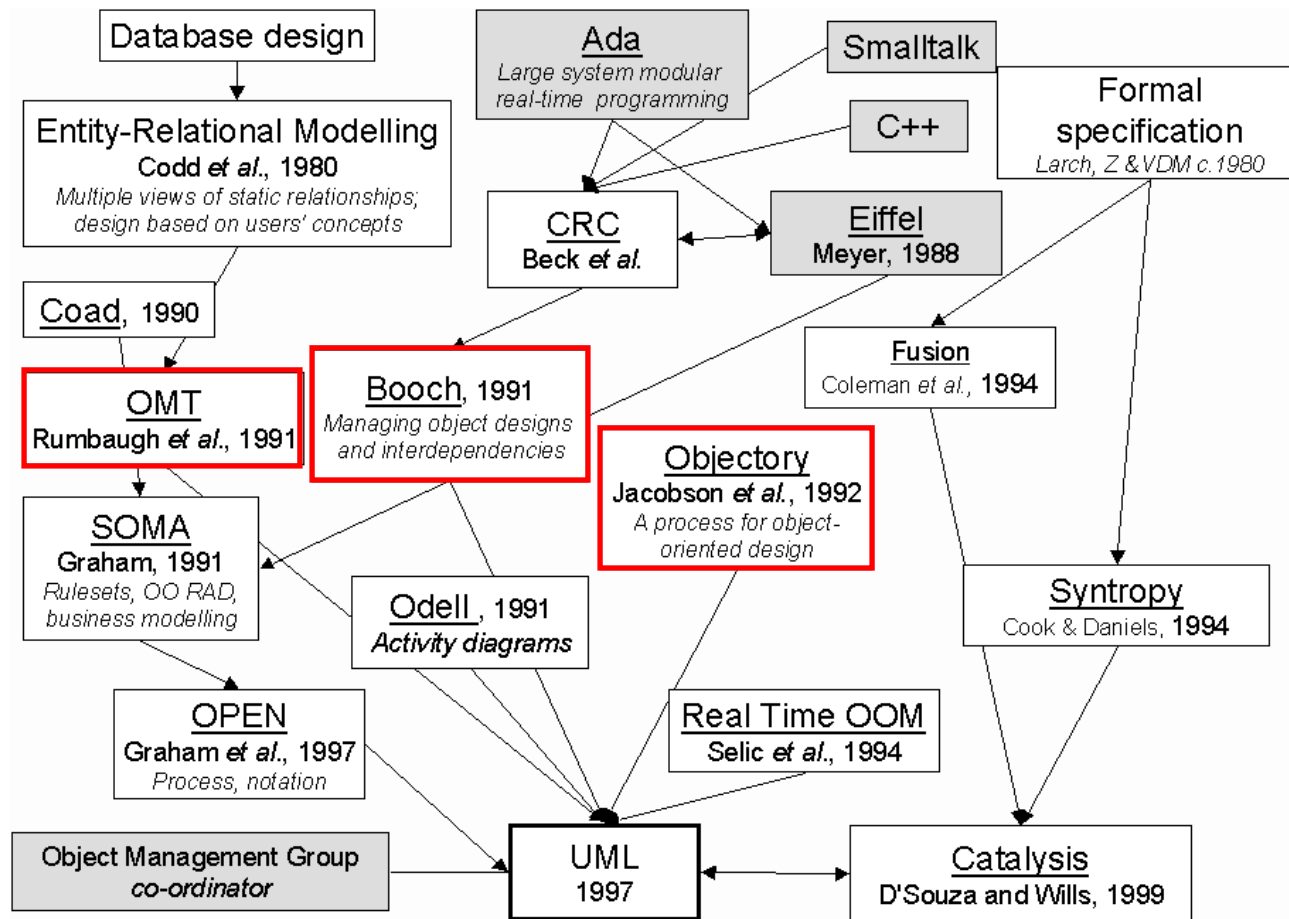

Figure 1, UML – a tutorial, ©1999 Trireme International

Types of Models

- Software Models
 - Models of the software system which developers use to build the system
- Ecological Model
 - Model of forest landscape and ecological processes, which the software must implement

Unified Process

- 1997 – UML specification
- 1998 – Rational Unified Process 5.0 (RUP)
- 1999 – *The Unified Software Development Process*
Unified Process (UP)
 - OMG's RFP for a Metamodel of Software Engineering Process
- 2000 – Unified Process Model (UPM) proposal
- 2002 – Software Process Engineering Metamodel (SPEM) specification

Levels of Viewing Software Development Processes

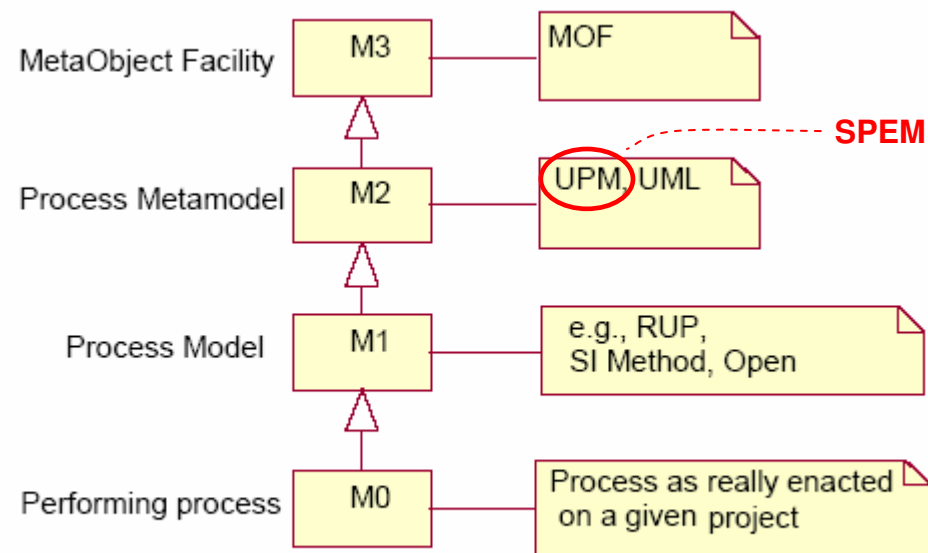
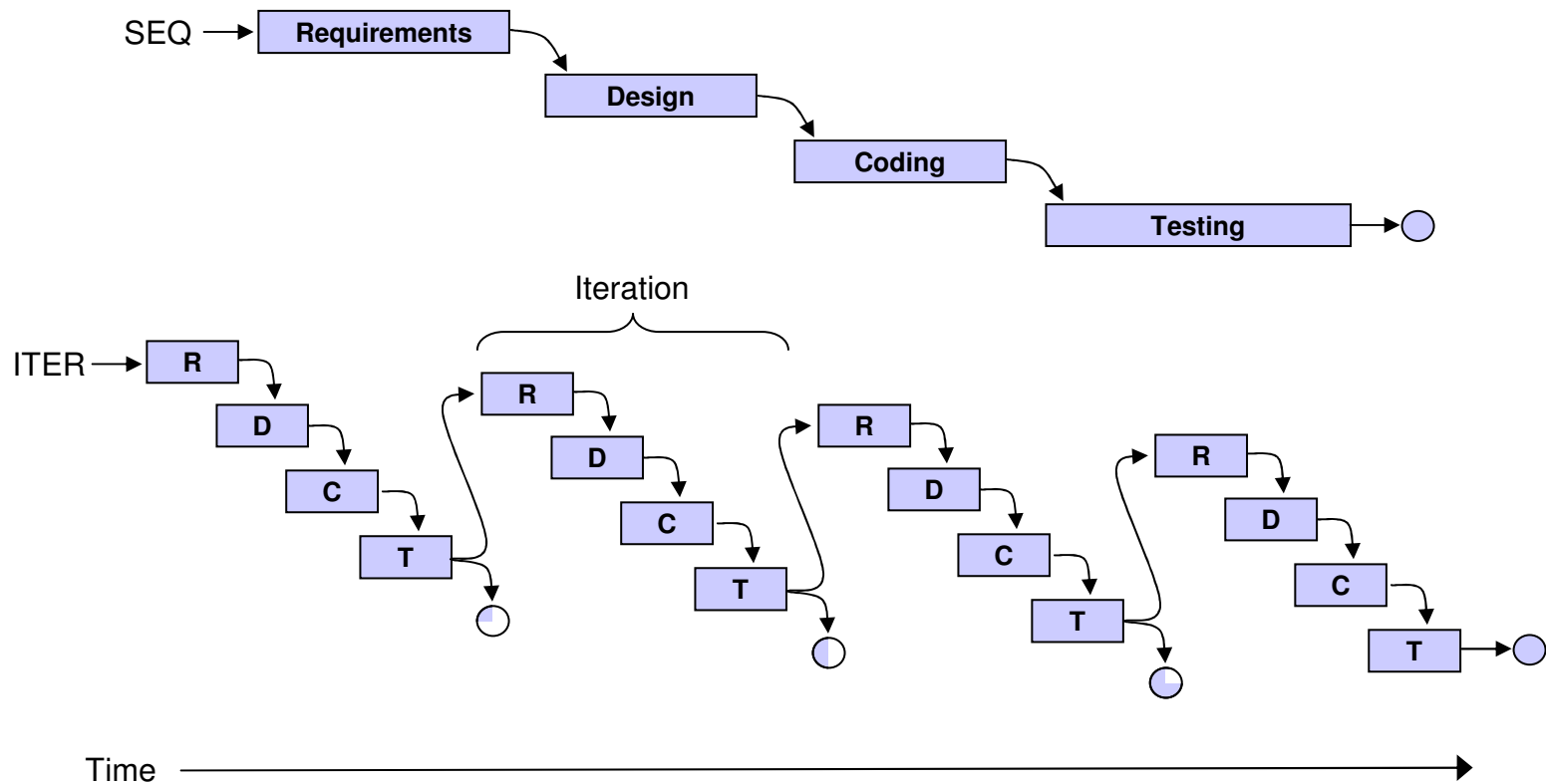

Figure 1-1 Levels of modeling

Unified Process

- Use-Case Driven
- Architecture-Centric
- Iterative and Incremental

Sequential vs Iterative Development



Unified Process – Phases

- Inception – *Establish a common vision*
- Elaboration – *Build and test the risky core*
- Construction – *Build and test the rest*
- Transition – *Deploy the system*

Phases & Iterations

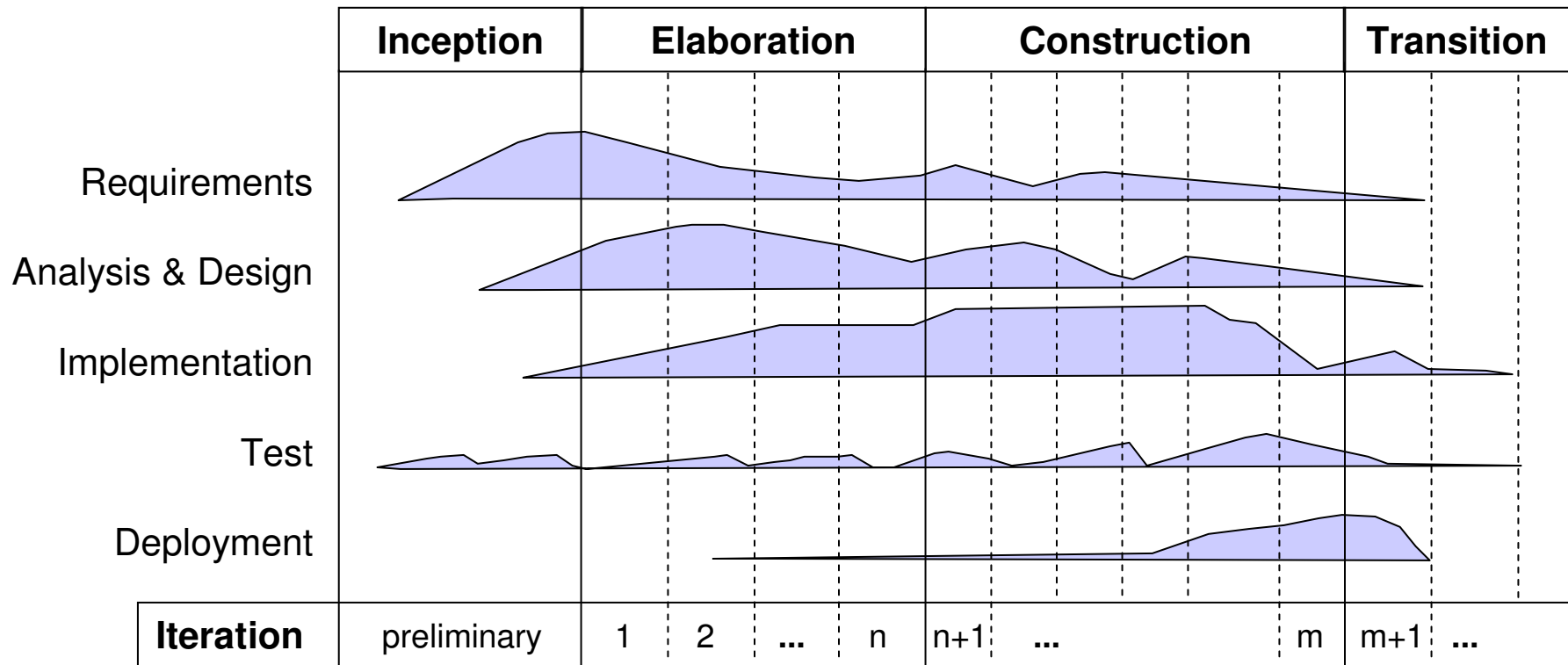

Based on Figure 9.5, Larman 2004 & EUP Lifecycle

Development Cycles

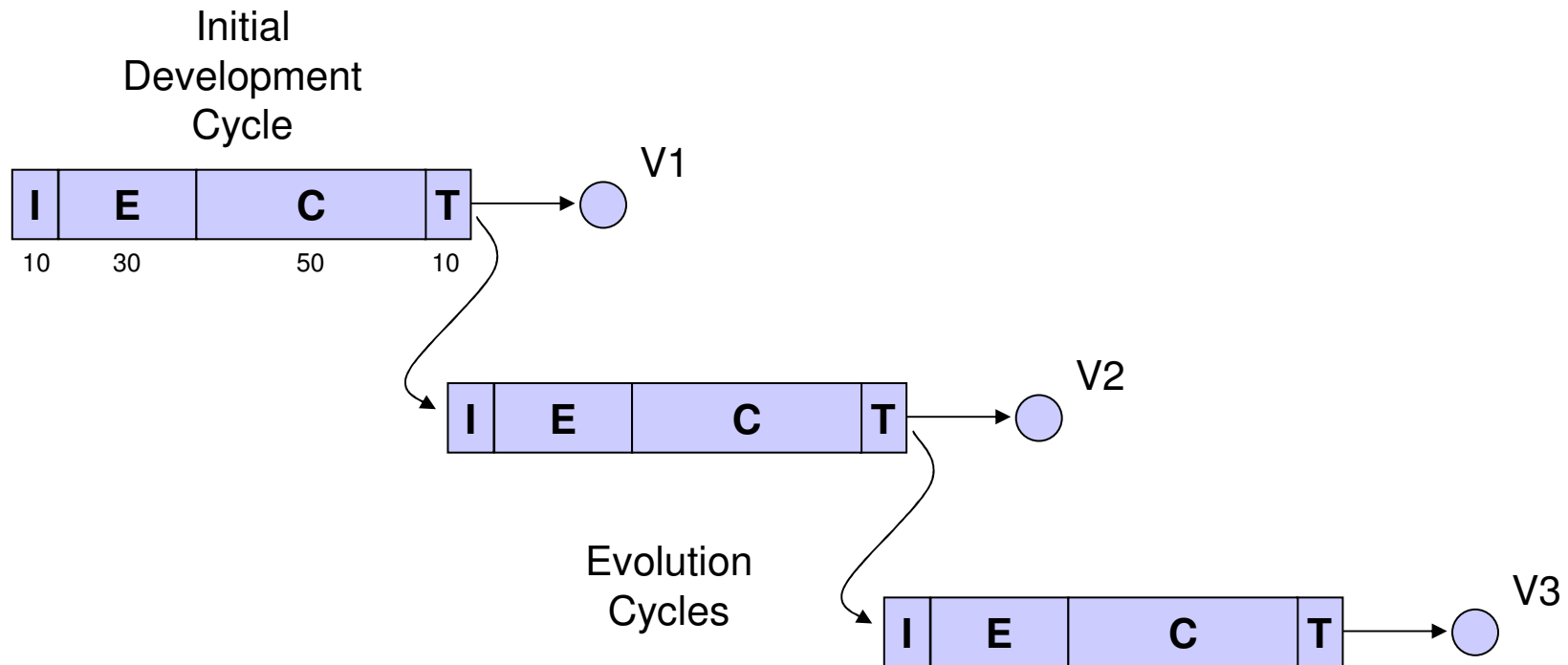

Process Goals for LANDIS-II

- Need to use a process
- Should facilitate primary objective:
Build working software
- Use a proven process
- Must be adaptable to our situation

UP & LANDIS-II

- Reassess commitment to UP
- Strategy for adopting UP